

**STEP 2.
INSERT GUSSET TAB IN
PLATE SLOT AND FILLET
WELD INTO PLACE.**

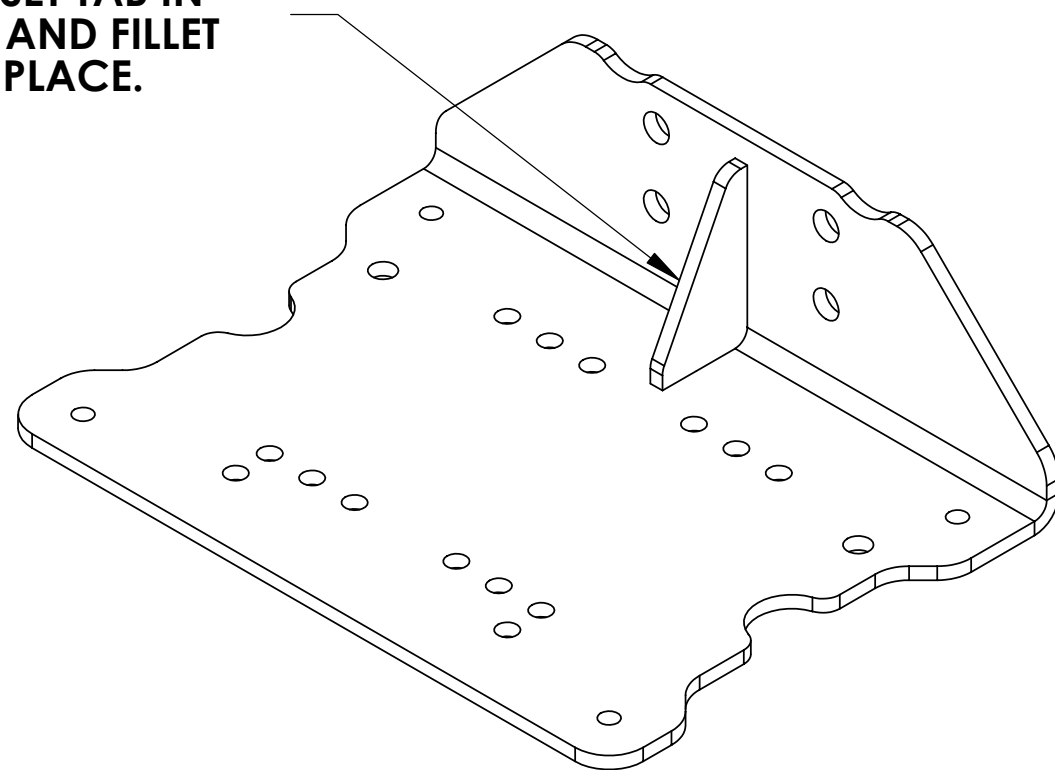

**STEP 1.
CHECK MAIN PLATE TO
VERIFY THAT IT IS SQUARE.
ADJUST WITH HAMMER IF
NECESSARY.**

TOLERANCES +/- UNLESS OTHERWISE SPECIFIED		MACHINING	WELDING	FABRICATING	FINISH REQUIREMENTS	USED ON REFERENCE MACHINE/DRAWING:
	DECIMAL	.03, .005	.13	.06		
	ANGLE					
THE INFORMATION CONTAINED IN THIS DRAWING IS THE SOLE PROPERTY OF PRECISION PLASMA LLC. ANY REPRODUCTION IN PART OR WHOLE WITHOUT WRITTEN PERMISSION IS PROHIBITED.						
	SCALE:	1:2	SIZE: B	DATE	NAME	MATERIAL:
	UNITS:	INCHES	DRAWN	7/15/17	RWC	
	SOLIDS (Y/N):	Y	CHECKED			
PRECISION PLASMA LLC.	TITLE:	MAGNUM 7 CARRIAGE WELDMENT			DRAWING NUMBER:	REV.
					MAG7-01	SHEET 1 OF 1