

DETAIL A  
SCALE 1 : 8

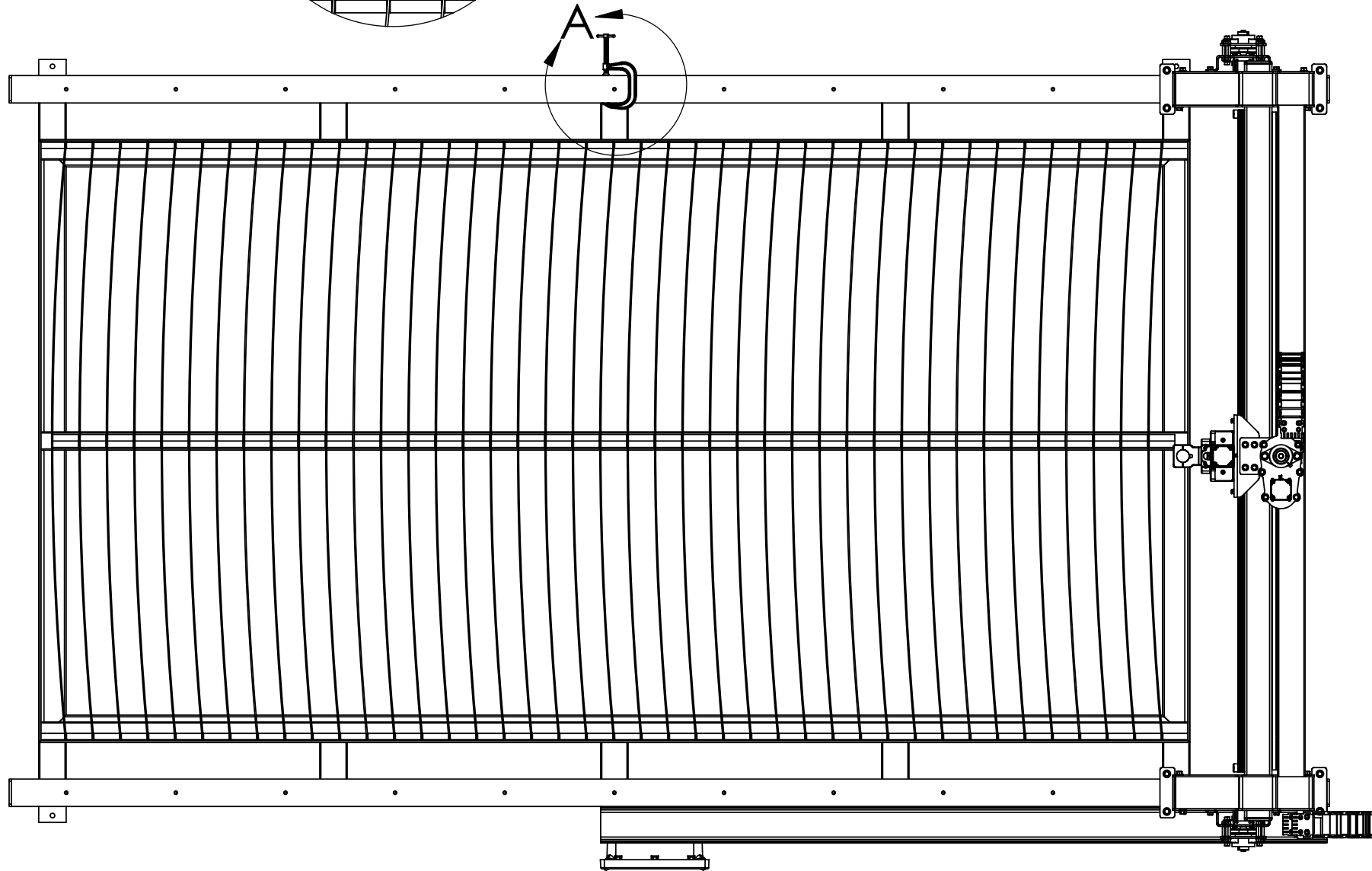
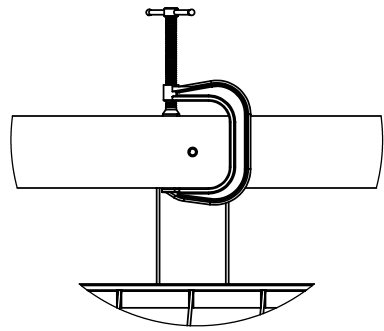

**CRS RAIL INSTALLATION:**

THE ACCURACY OF THE TABLE IS DIRECTLY RELATED TO THE TABLE RAIL INSTALLATION, SO CARE MUST BE TAKEN TO ACCURATELY INSTALL THE RAILS.

THE RAILS ARE INSTALLED AT ASSEMBLY AND THE FOLLOWING PROCEDURE SHOULD BE FOLLOWED.

1. LOCATE THE STRAIGHTEST RAIL AND SET ON FRAME FLUSH WITH OUTSIDE 3X3 TUBE.
2. CENTER PUNCH, DRILL, AND TAP 5/16-18 HOLES IN THE END (2) HOLES OF THE RAIL AND INSTALL BUTTON HEAD SCREWS.
3. USING A STRING, STRAIGHT EDGE, LASER, OR SIGHT TO DETERMINE IF THE RAIL IS BOWED. IF IT IS, PULL THE CENTER OF THE RAIL OVER WITH A C-CLAMP TO BE STRAIGHT.
4. DRILL AND TAP REMAINING HOLES AND INSTALL SCREWS.
5. SET SECOND RAIL ON FRAME AND MEASURE FROM FIRST RAIL TO BE PARALLEL WHEN INSTALLING SECOND RAIL SCREWS.
6. INSTALL GANTRY ON FRAME AT ONE END WITH GANTRY AGAINST END STOPS AND CENTERED BETWEEN SIDE RAILS.
7. INSTALL SIDE GUIDE BEARINGS AGAINST RAILS USING A 9/16" WRENCH ON TOP AND BOTTOM. LOOSEN THE BOLT, ANGLE BOLT TOWARDS RAIL, AND TIGHTEN THE LOWER NUT. THIS PROCEDURE WILL PREVENT THE BEARING FROM WALKING AWAY FROM THE RAIL.
8. LOOSEN THE SCREWS HOLDING THE SECOND RAIL.
9. ROLL THE GANTRY DOWN THE RAIL AND TIGHTEN THE SECOND RAIL SCREWS AS THE GANTRY MEETS THEM. THIS WILL USE THE GANTRY AS A FIXTURE TO EXACTLY PARALLEL THE RAILS.

**NOTE:**

**THE CRS RAILS ARE DESIGNED TO BE THE SAME WIDTH AS THE FRAME. HOWEVER, THE FRAME MAY NOT TURN OUT PERFECT, SO IT IS MORE IMPORTANT FOR THE RAILS TO BE PARALLEL. THE GANTRY HAS TOLERANCE BUILT IN SO THAT THE OVERALL DIMENSION CAN VARY BY UP TO 1/4"**

TOLERANCES +/- UNLESS OTHERWISE SPECIFIED		MACHINING	WELDING	FABRICATING	FINISH REQUIREMENTS	USED ON REFERENCE MACHINE/DRAWING:
	DECIMAL	.03, .005	.13	.06		
	ANGLE					
THE INFORMATION CONTAINED IN THIS DRAWING IS THE SOLE PROPERTY OF PRECISION PLASMA LLC. ANY REPRODUCTION IN PART OR WHOLE WITHOUT WRITTEN PERMISSION IS PROHIBITED.						
	SCALE:	1:16	SIZE: <b>B</b>	DATE	NAME	MATERIAL:
	UNITS:	INCHES	DRAWN	7/15/17	RWC	
	SOLIDS (Y/N):	Y	CHECKED			
PRECISION PLASMA LLC.	TITLE:	MAGNUM 7 5X10 TABLE ASSEMBLY			DRAWING NUMBER:	REV.
					<b>CRS INSTALLATION</b>	1 OF 1