

THIS PRINT FOR MAGNUM 7 STEEL GANTRY ONLY

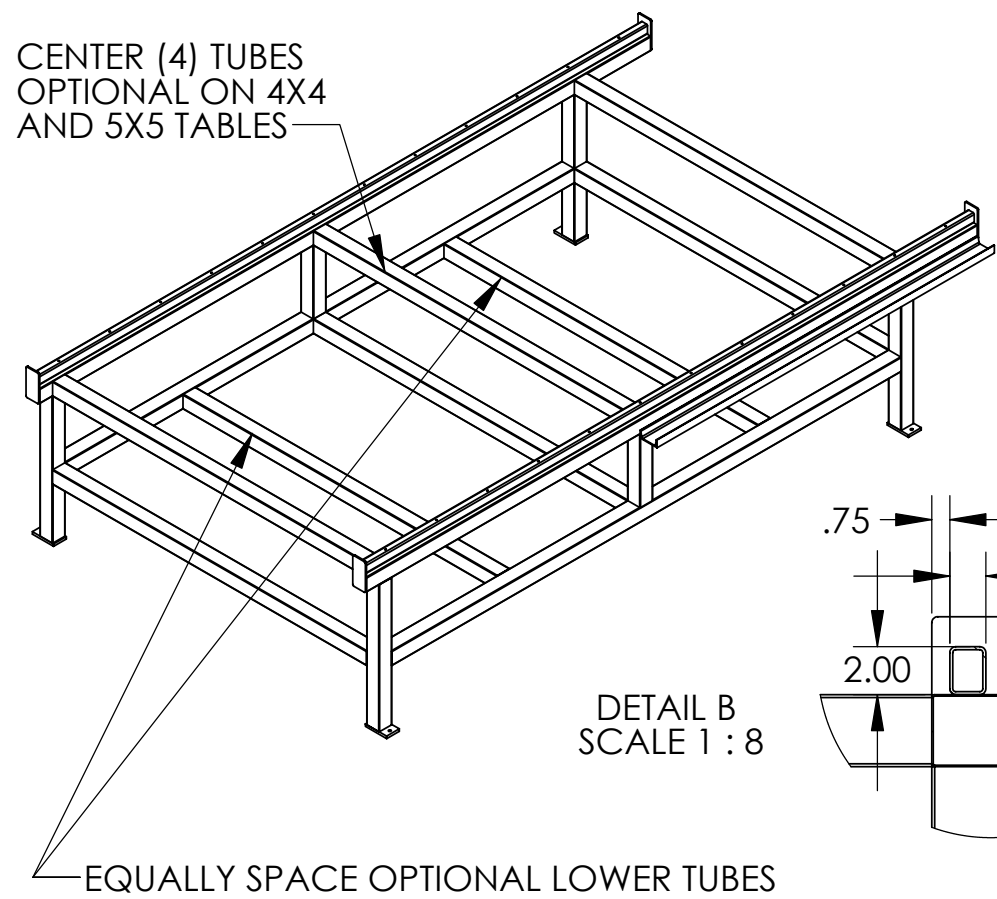

DETAIL B
SCALE 1 : 8

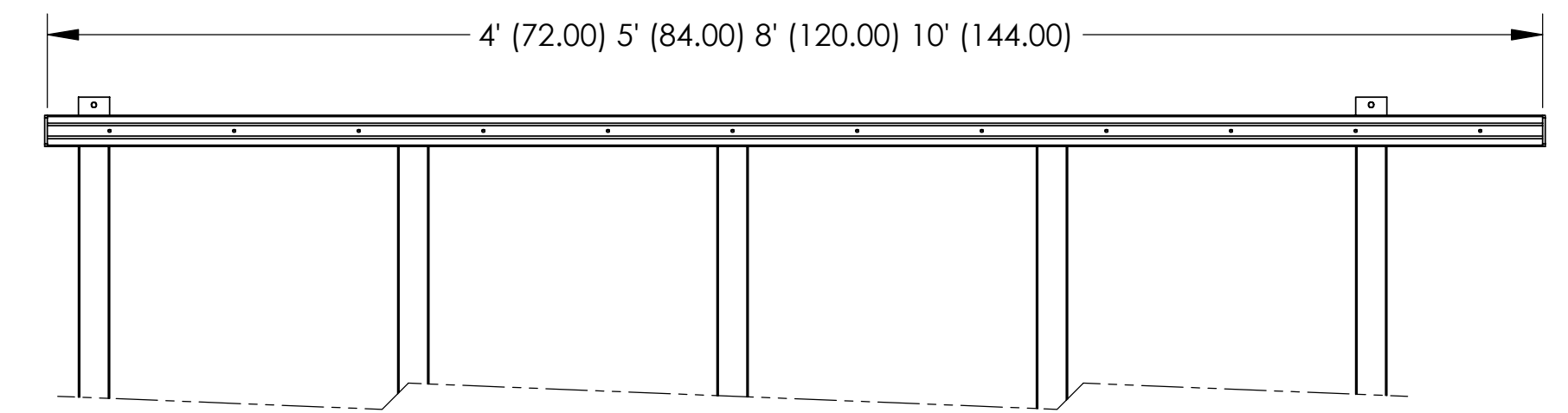
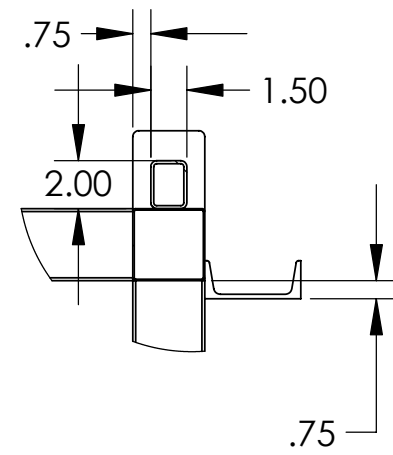

NOTE: BE SURE TO MEASURE CORNER TO CORNER OF FRAME TO VERIFY IT IS SQUARE BEFORE WELDING

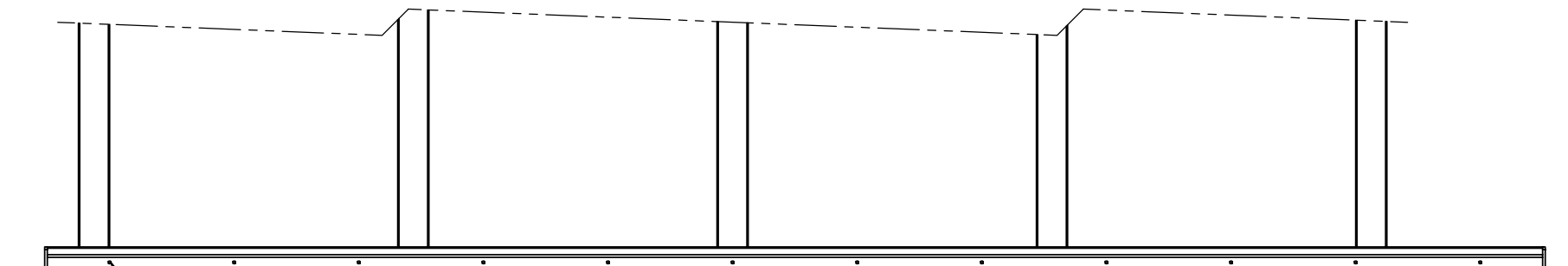

CHANNEL CAN BE WELDED ON EITHER SIDE OF FRAME
FOR LEFT OR RIGHT SIDE ELECTRICAL ENCLOSURE

4' (72.00) 5' (84.00) 8' (67.50) 10' (79.50)

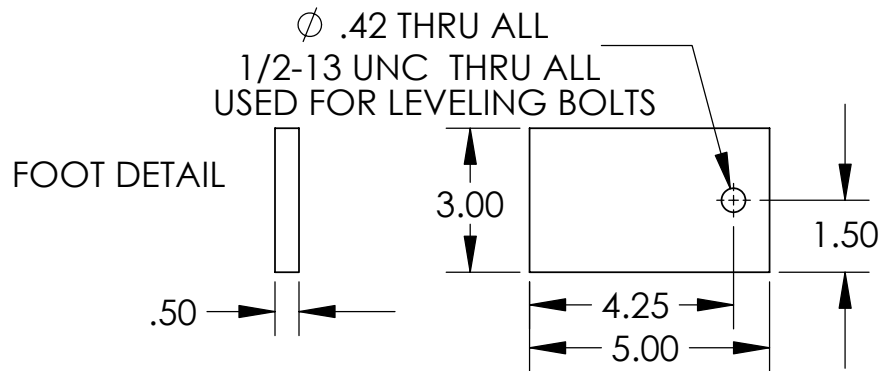
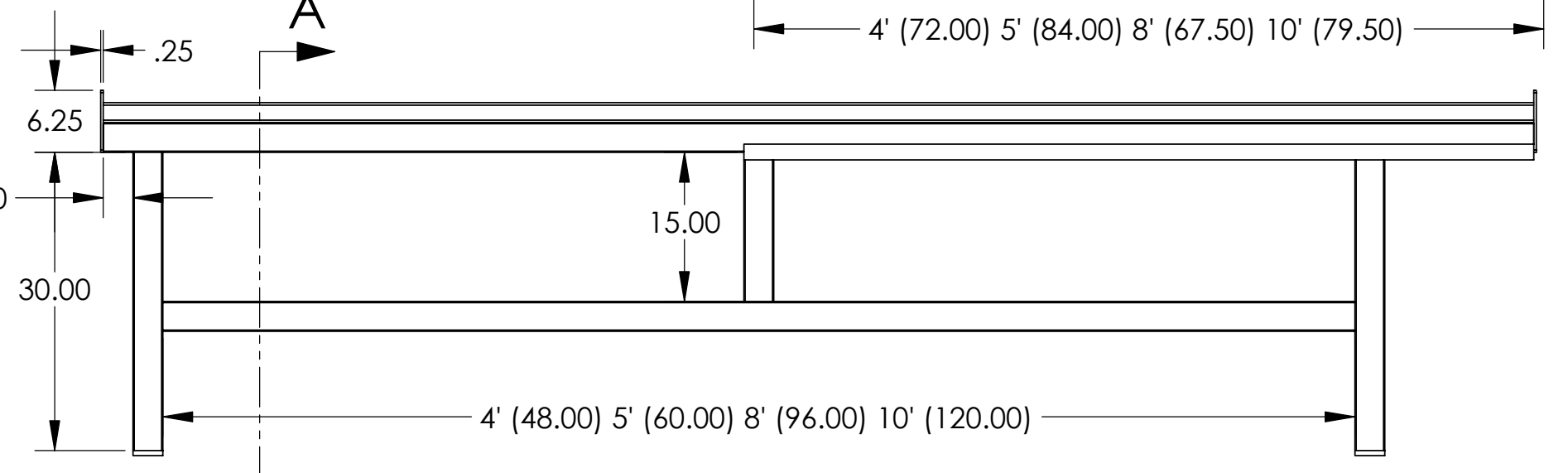
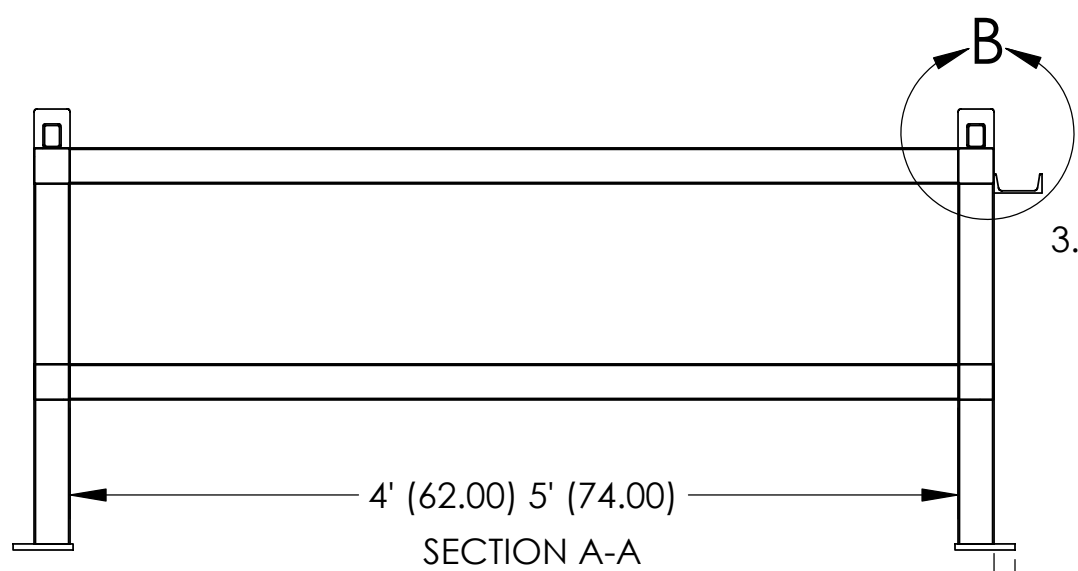

1.5 X 2 X 1/8" WALL TOP TUBES
3X3 X14 GAGE WALL FRAME TUBES

TOLERANCES +/- UNLESS OTHERWISE SPECIFIED	MACHINING	WELDING	FABRICATING	FINISH REQUIREMENTS PAINT	USED ON REFERENCE MACHINE/DRAWING:
	DECIMAL	.03, .005	.13		
	ANGLE				
THE INFORMATION CONTAINED IN THIS DRAWING IS THE SOLE PROPERTY OF PRECISION PLASMA LLC. ANY REPRODUCTION IN PART OR WHOLE WITHOUT WRITTEN PERMISSION IS PROHIBITED.					
	SCALE: 1:16	SIZE: B	DATE	NAME	MATERIAL:
	UNITS: INCHES	DRAWN	7-9-17	RWC	
	SOLIDS (Y/N): Y	CHECKED			
PRECISION PLASMA LLC.	TITLE: MAGNUM 7 LOWER FRAME 3 INCH TUBING			DRAWING NUMBER:	REV.
				MAG7 LFRAME	SHEET 1 OF 1

THIS PRINT FOR MAGNUM 7 STEEL GANTRY ONLY